



WESTATE DIESEL SYSTEMS

Centrifugal Filtration for Lubricants and Fluids
Mining - Industrial - Marine - Agriculture - Automotive

Model 996 Installation Instructions, Parts List and Service Instructions

Three connections are required at the centrifuge:

1. Oil Inlet (3/4"- 16 UNF Female SAE J514-8 O-ring) - *Unscrew plastic shipping plug.* Run #8 hose from point of highest pressure.
2. Oil Outlet (3/4"- 16 UNF Female SAE J514-8 O-ring) - *Unscrew plastic shipping plug.* Run #8 hose to crankcase above oil level.
3. Air Inlet (1/4" NPT Female Pipe) - *Unscrew plastic shipping plug.* Run #4 hose from any convenient point on air supply to air valve cartridge inlet. *Do not remove cartridge — loss of cartridge seal will damage unit.*

CAUTION — Route hoses to clear exhaust and all moving parts and fasten securely. Be certain pressure oil supply is to OIL IN port on side of centrifuge and return to crankcase is from OIL OUT port on bottom. *Do not remove full-flow filters.* Use the Spinner II centrifuge *only* as a by-pass oil cleaner. Remove any previously installed bypass filters prior to installation of the Spinner II, and block ports where necessary.

Spinner II/996 Net Weight 11.02 lb (5.0 kg)

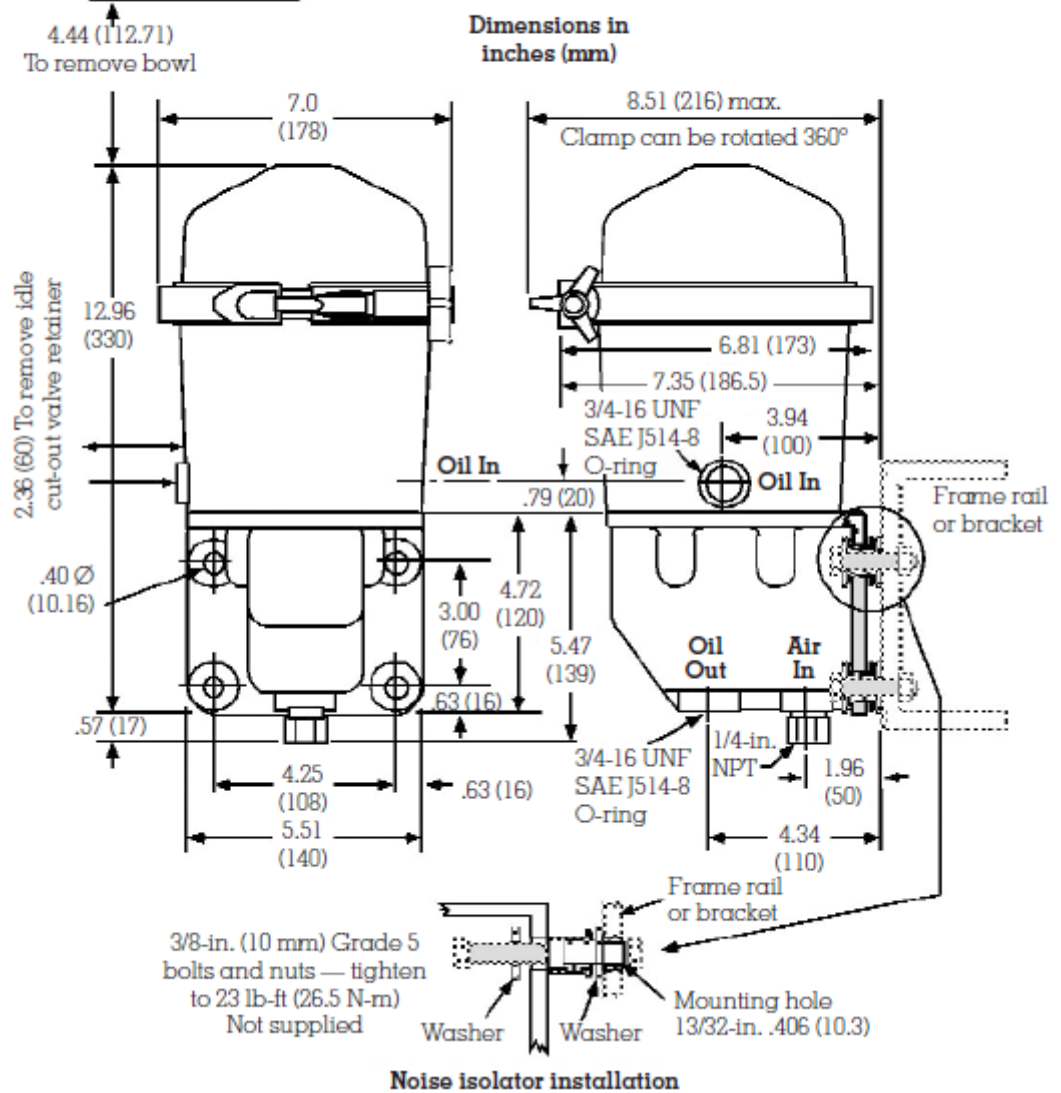

Detailed Information Available

For optimum performance of your centrifuge, specific installation drawings for most diesel engines can be requested from Westate Diesel Systems.

General Instructions

Dirty Oil Supply to Centrifuge Oil Inlet Pressure Tap on Engine - Most engines, including the latest models from Cummins, Caterpillar, DDC and Mack, provide a 3/8" or 1/2" port to supply an auxiliary device.

Avoid using end-of-gallery supply points such as the pressure gauge tap. **Note on COV (Cut-Out Valve):** Idle cut-out valve prevents oil flow into centrifuge at pressures less than 19 psig.

Clean Oil Outlet Return to Crankcase Return Opening in Crankcase - Most engines have a 1/2" or larger oil return opening provided in the crankcase wall. If unrestricted, this is an ideal oil outlet line connection point.

Special Return Problems - If there are no available drain openings, it may be necessary to drill and tap an inspection plate. Remove the plate before modification and avoid directing the return flow directly onto moving parts.

Air Supply

Air for the control mechanism can be taken from any convenient place on the vehicle air system where there is a constant supply of air, preferably from the dry tank.

1/8" nylon tubing is sufficient or #4 hose can be used if preferred. Air pressure can vary from 2 to 25 psig. No regulators, valves or control devices are required. The Spinner II control automatically shuts off the air supply when the engine stops. 0.02 SCFM air consumption is almost too small to measure.

Mounting Location

Install vertically $\pm 10^\circ$. The frame rail is the preferred location for mounting the centrifuge. A Spinner II Part 70845 spacer is available to facilitate inside frame rail mounting, requiring only two holes in the rail. Check with manufacturer before drilling. **Below contains a drilling template.** Additionally, a Spinner II Part 71421 No-Drill mounting bracket kit is also available. Use this kit when installation will not permit drilling of the frame rail.

The Spinner II centrifuge is a high-speed device and is provided with noise isolators for operator comfort, which must be installed as shown above. Care should be used to prevent metal-to-metal contact with the frame or body, which might result in unnecessary noise or vibration. The cover clamp can be rotated to any convenient position and tightened by hand only.

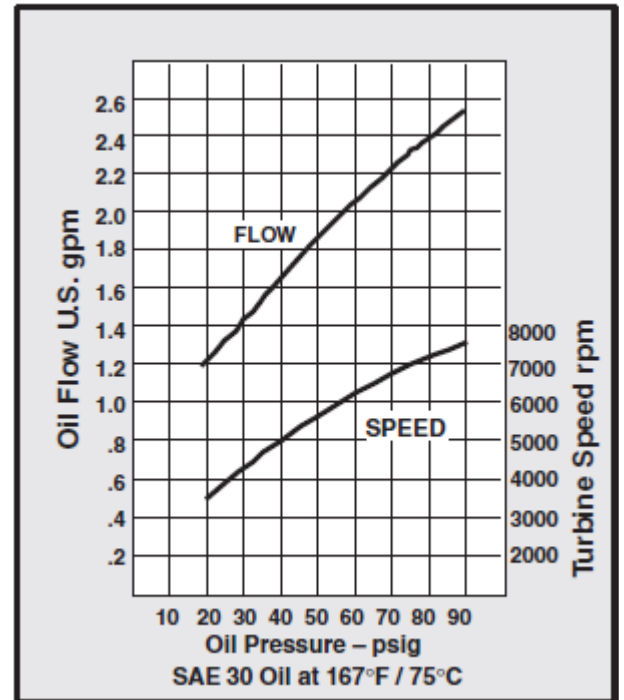

Cont.

Model 996 Parts List

Item	Description	Part number
Only items shown with part numbers are available. Bold denotes assembly		
	Centrifuge, Spinner II/Model 996 complete	73210
	Service kit, clean bowl (1 each items c, l, n and t)	73265
a	Cover	73191
b	Clamp, cover to base	71281
	Tee bolt and knob clamp	71282
c	Seal-cover, Viton*	71264
	Cover assembly	73267
h	Nut-centrifuge bowl	73239
k	Bowl-centrifuge	73196
l	Insert, paper-centrifuge bowl (pkg. of 50)	73165
n	Seal-centrifuge bowl, Viton	73240
m	Baffle/screen-centrifuge	73197
u	Body-centrifuge turbine	73194
d	Centrifuge turbine assembly	73193
	(includes items h, k, l, m, n and u)	
e	Housing assembly	73234
■ s	Repair kit-idle cut-out valve	71053
t	Seal-idle cut-out valve	71054
g	Control mechanism assembly	71286
	Screw, hex head cap-control mechanism	70673
	M10 x 35 mm (available locally)	
■ f	Seal-control mechanism (Viton)	70996
	Repair kit-control float mechanism	71445
p	Kit-isolator, noise, with washers (set of 4)	71173
	($\frac{1}{2}$ -in. grade 5 bolts and nuts not supplied)	
■ q	Cartridge-air valve assembly (includes item r)	70938
	(optional assembly for turbo air supply - 72137)	
r	Seal-air valve cartridge, Viton	70966

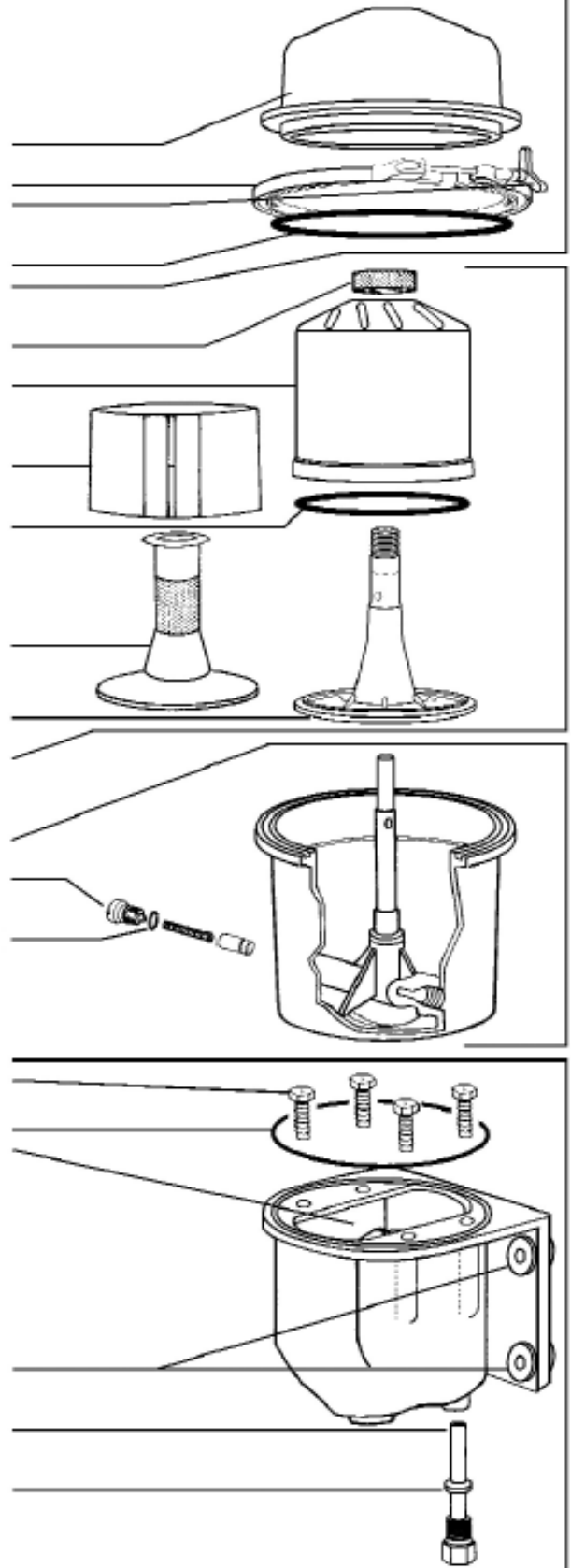

Service Cycle ■ At unit rebuild or when required.

1. Shut off engine and allow centrifuge turbine assembly **(d)** to come to a complete stop.
2. Loosen handle on clamp **(b)**, disengage tee bolt and remove cover **(a)**, using coin in gap to separate cover from housing.
3. Partially withdraw centrifuge turbine assembly **(d)** from the housing **(e)** and allow oil to drain from nozzles **(o)** before removing completely.
Hold the centrifuge turbine assembly in one hand and loosen knurled bowl nut **(h)** several turns until the face of the nut projects beyond the bronze bushing face. Carefully separate centrifuge bowl **(k)** from turbine base **(u)** by striking the face of the nut **(h)** with the palm of one hand while holding the bowl in the other. *Do not strike the nut or the bushing with or against a hard surface or damage will result.* Finish removing the nut and then remove the bowl and baffle/screen **(m)**.
4. Simply replace the dirty centrifuge bowl with a new one **or** carefully remove the dirt cake from the bowl **(k)** using a wooden spatula or other non-damaging tool. Wipe out bowl with solvent. *Note:* To save time in cleaning, an optional die-cut Bristol paper insert **(l)** is available as a service part and may be installed to allow the compressed cake to be removed quickly.

5. Wash and clean baffle/screen **(m)** and turbine base **(u)**. Examine the Viton seal and replace, if damaged. The seal is Viton and can be reused several times.

6. Inspect top and bottom bushings of centrifuge turbine base **(u)**. Replace turbine assembly if bushings show severe wear. Reassemble: Place baffle/screen **(m)** over stem of turbine body and seat evenly over shoulder on base. Install bowl seal **(n)** in recess in outer edge of turbine base. Slide a new centrifuge bowl **(k)** over stem and seat uniformly over bowl seal. Install and tighten knurled bowl nut **(h)** securely, *using finger pressure only.*

7. Inspect housing assembly **(e)** paying special attention to journal areas of spindle. Replace housing if damaged.

8. Clean and inspect cover **(a)**. Always remove the old cover seal **(c)**, clean the groove in the housing and mating surface of the cover.

Examine the Viton seal and replace, if damaged. The seal is Viton and can be reused several times.

9. Check control mechanism **(g)** — see diagram above.

10. Install centrifuge turbine assembly **(d)** on spindle. Be sure it rotates freely. Replace cover **(a)**, position clamp **(b)** uniformly over cover and housing flanges, and tighten clamp handle securely *by hand pressure only.*

Top view with centrifuge removed

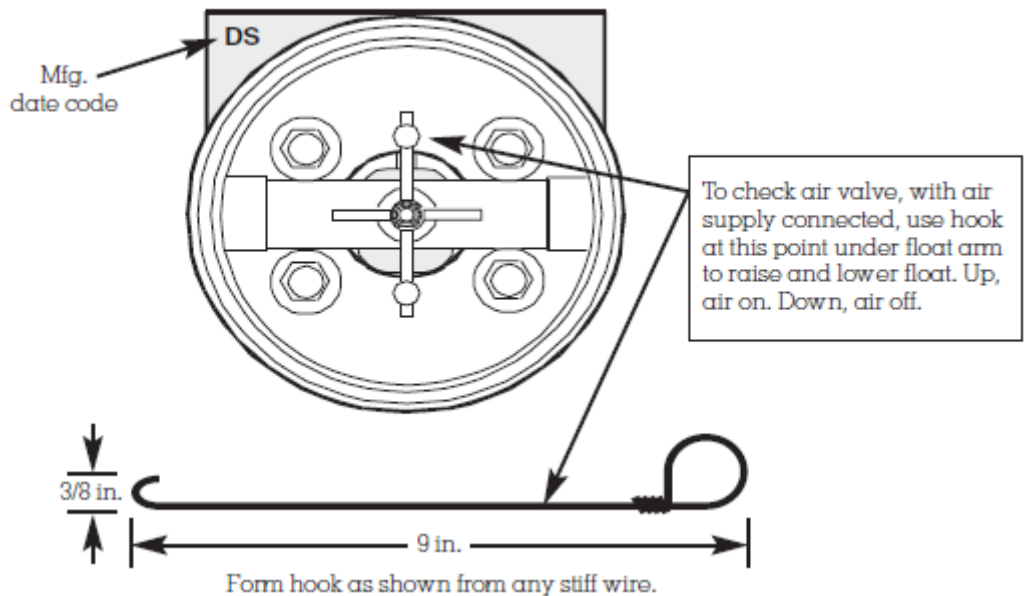

11. Remove, clean and inspect the idle cut-out valve assembly **(s)** and mating bore in housing. Correct any problems, renew seal **(t)** and replace assembly.

12. With the engine running, check all connections and joints for leaks.

Trouble-Shooting

Centrifuge removes too little dirt

Check for Proper Operation

Warm up engine and then bring engine to normal speed for one minute and immediately shut it down. If the Spinner II unit is working correctly the turbine can be heard spinning. As with any high-speed device, it may go through momentary periods of vibration as it passes through critical speeds while slowing to a stop. This is normal. If the turbine is not spinning or if vibration is severe or continuous at all speeds, an error may have been made in assembly. Repeat steps 1 to 10, paying special attention to the proper seating of baffle/screen **(m)**, the bowl seal **(n)** (Step 6) and the control mechanism (Step 9). If vibration persists, substitute a different centrifuge turbine assembly **(d)**.

If the turbine is spinning properly, the centrifuge is doing its job of removing harmful abrasive dirt regardless of the amount of deposit found in the bowl. The visible deposit is largely soot and its thickness will vary from 1/16-in. to completely full depending on oil type, oil change interval, engine type and condition, and operating conditions.

Control air valve problems

Float valve flows air constantly or not at all, up or down.

Air tank bleeds down overnight.

Check Valve (Step 9)

Most air control problems can be repaired without dismounting the centrifuge by renewing the air valve cartridge **(q)**, making certain that air valve cartridge seal Part 70966 **(r)** is in place. A cartridge installed without the seal will be damaged and will leak continuously. If the float mechanism is worn or broken, the centrifuge must be disassembled and repaired with control float mechanism repair kit Part 71445.

Instructions are contained in the kit. Caution: The valve cores in the air valve cartridge are special, low operating force-type with Viton seals to withstand hot oil. *Do not substitute tire valve cores — replace the entire cartridge.*

Oil leaks

Cover Seal

Remove cover **(a)** and cover seal **(c)**. Clean seal grooves in housing and mating surface on cover. Install a new cover seal **(b)** in the housing groove, replace cover **(a)**, position clamp **(b)** uniformly over cover and housing flanges, and tighten clamp handle securely *by hand pressure only*.

Body to Control Mechanism Seal

Remove cover and centrifuge turbine assembly. Remove control mechanism by loosening four cap screws. Discard seal **(f)** and clean groove and mating surfaces. Replace seal with a new one and retighten cap screws alternately to 35 lb-ft torque. It is possible to rotate the body 180° if it is necessary to locate the oil inlet port on the left side. Replace the seal and retighten bolts. Continue from Step 3 above.

Oil Line Connections

Disconnect leaking hose and remove hose adapter from port.

Clean threads in port and on adapter, and inspect for damage.

Reinstall adapter using a good liquid thread sealant. Reconnect hose.

Made in England by Mann+Hummel (UK) Ltd. Patented worldwide.

©Viton is a registered trademark of E.I. DuPont de Nemours & Co., Inc.

©Spinner II is a registered trademark of T.F. Hudgins, Incorporated.

©2002 T.F. Hudgins, Incorporated. All rights reserved.

Litho in U.S.A. Bulletin 73264/9-02

WESTATE DIESEL SYSTEMS
Michael Stocker
Mobile 0457 983 052 Fax: 08 9572 2940
michael@westatesystems.com.au
Administration: admin@westatesystems.com.au
ABN: 40947397448

Cover Clamp Model Installation Tips

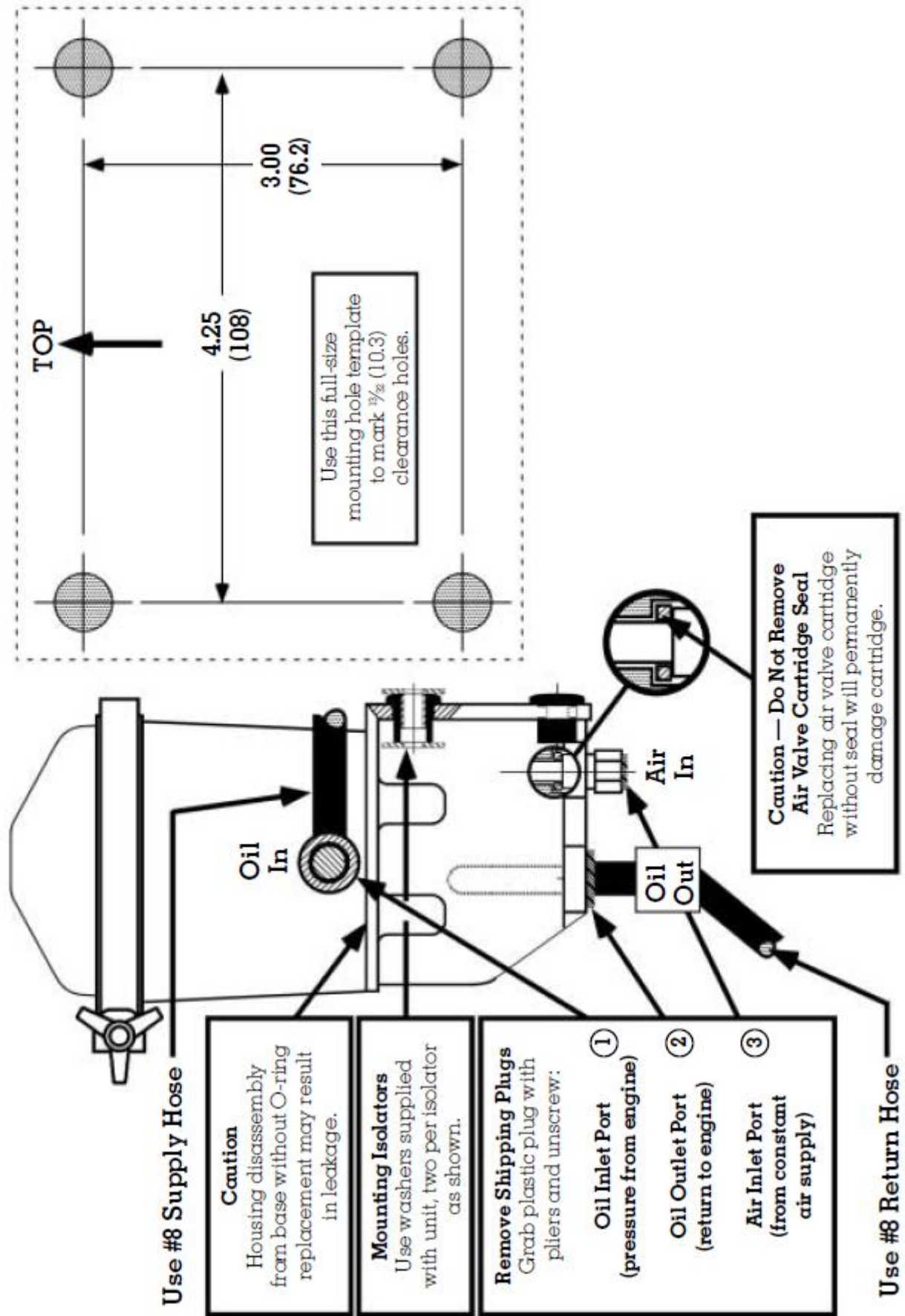

Use #8 Supply Hose

Caution
Housing disassembly from base without O-ring replacement may result in leakage.

Mounting Isolators
Use washers supplied with unit, two per isolator as shown.

Remove Shipping Plugs
Grab plastic plug with pliers and unscrew:

① Oil Inlet Port (pressure from engine)

② Oil Outlet Port (return to engine)

③ Air Inlet Port (from constant air supply)

Use #8 Return Hose